

Size		11	12	15	21	22	24	26	28	120
Torque	Mu (Nm)	100	200	350	600	1200	2200	3000	4000	6000
DC Voltage	(V)	24 V DC								
Power Consumption	(W)	17	24	42	49	69	77	87	100	140
Weight approx..	(kg)	0.96	1.23	2	3.4	5.6	8.5	11.7	17.5	20
Magnet Side		0.9	1.5	3.8	9	18.5	38	60	108	105
Moment of inertia	(10 ⁻³ kgm ²)	0.3	0.6	1.5	4.2	10.0	20	36	63	79
Armature Side										
	Ø D ₁ /D ₂ (mm)	82	95	114	140	166	195	210	240	258
	A (mm)	39	40	47	54	60	67	77	84	90
	A ₁ (mm)	42	43	50	57	63.5	70	79	86.5	92.5
	ØD ₃ (mm)	67	78	95	120	142	170	184	216	234
	Ød ₁ (mm)	31	37	45	60	65	100	90	100	130
	Ød ₂ K6 (mm)	35	42	55	68	75	110	100	110	140
	Ød ₃ +/-0.1 (mm)	50	56	75	90	100	125	130	145	200
	Ød ₄ (mm)	M5	M6	M8	M8	M10	M10	M12	M12	M12
	Ød ₅ +0.2 (mm)	35	45	53	70	80	110	100	112	133
	Ød ₆ (mm)	M4	M4	M4	M5	M6	M6	M6	M6	M6
	Ød ₇ ±0.1 (mm)	55	65	80	100	120	150	150	150	170
	f (mm)	25	25	30	33	35	37.5	42	45	52
	g (mm)	22.5	22	25	28	30	34	39	40	41
	h +0.2 (mm)	20	20	22	22	25	28	31	32	33
	k (mm)	7.5	7.5	11	11	13	13	14.5	14.5	14.5
	l (mm)	5	5	6	8	9	14	16	18	13
	u+0.1 (mm)	2.5	2.5	5	5	6	6	6	6	8
	V ^{H7} (mm)	12	12	14	16	20	20	20	25	25
	y (mm)	0.3	0.4	0.4	0.4	0.5	0.5	0.5	0.5	0.6
	n (mm)	6	6	7	8	9.5	12	14	14.5	16.5

* The holes for attaching the adapter plate to the item of machinery must be made by the customers

* Special Voltage Clutches available on request.

* Keyways BS 4235, DIN 6885

* Technical Alteration reserved.

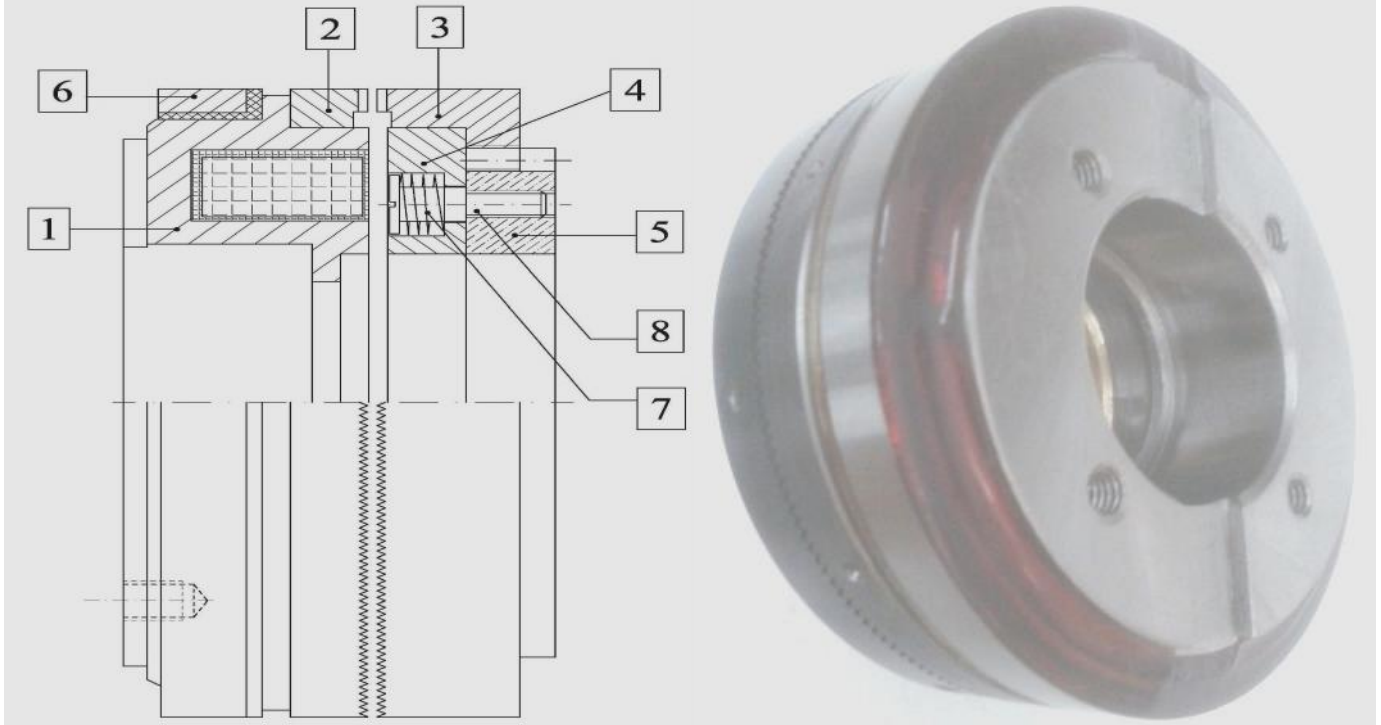

nmnn
n

CONSTRUCTION

- | | | | |
|------------------|-------------------------|-------------------|------------------------|
| (1) Coil Housing | (3) Armature Drive Ring | (5) Adapter Plate | (7) Compression Spring |
| (2) Drive Ring | (4) Armature Plate | (6) Slip Ring | (8) Screw |

OPERATION: This Toothed clutch comprises a coil Housing (1) containing a potted coil, a face teeth drive ring (2) and slip ring (6) mounted on the coil housing outside. Coil Housing is bolted to the machinery part with which it must rotates. Armature drive ring (3) is press fitted on armature plate (4) and these two slides on spur gear provided on adapter plate (5). Adapter plate is connected to the driving shaft by means of additional flange. Adapter Plate is supplied without mounting holes. Required Mounting hole and finish bore can be made by the user. Spring (7) and screw (8) ensure that the two toothed rings are kept apart when the clutch is de energized. Face Teeth are machined on faces of the drive ring and armature drive ring.

Energization of the coil through slip ring by telescopic brush (refer page 37 for brush details) generates a magnetic field which attracts the sliding armature plate and armature drive ring. The face teeth mesh together and this allows the driving torque to be transmitted. For disengagement all that is necessary is to switch off the power supply. Armature drive ring is retracted into rest position by means of the screw and springs.

APPLICATION: Engagement at Rest or at a relative speed of +/-5r.p.m of the shafts but may be disengaged at any speed or under load. Nil residual torque. Operation is possible in both wet and dry condition.

EXAMPLE OF INSTALLATION

The Basic Version of Clutch for Torque transmission between shaft and gear wheel.

This version of the toothed clutch is designed so that the magnetic body also serves to accommodate the bearings.

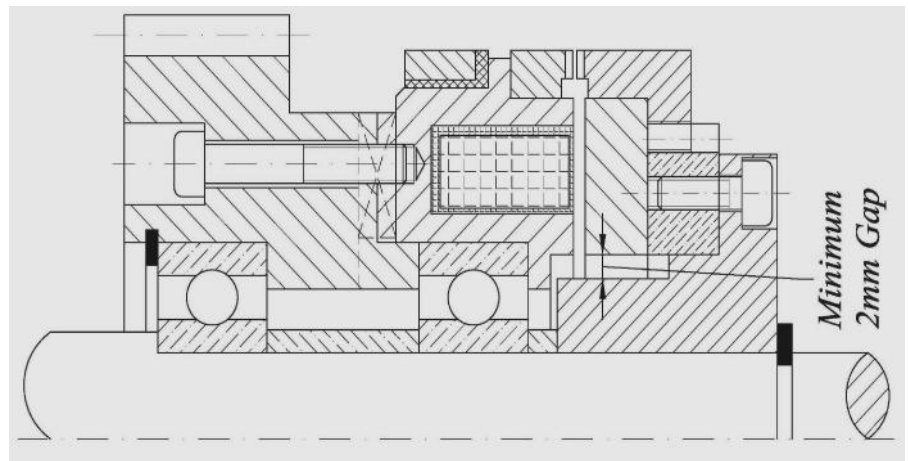

ORDER EXAMPLE.

Electromagnetic Slip Ring Toothed Clutch with Back Slot

TYPE : 24.503.26.2 – 24 V.d.c